



Quick change tapping chucks **with** length compensation on compression and expansion

Mandrins de taraudage à changement rapide **avec** compensation longitudinale à la compression et traction

2



Verwendung:

Zur Aufnahme von Schnellwechsel-Ein-sätzen für Gewindebohrer.

Application:

For the chucking of quick change adaptors for taps.

Application:

Pour le serrage d'adaptateurs porte-tarauds à changement rapide.

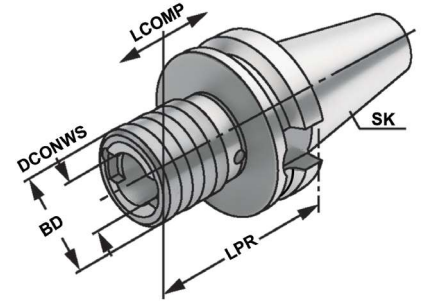

Bestell-Nr. Order no. Référence	SK	Spannbereich Capacity Capacité	SZID	DCONWS	LPR	BD	LCOMP
305.16.12	BT 30	M3 - M14	1	19	64	36	7
305.16.20	BT 30	M5 - M22	2	31	95	53	12
405.16.12	BT 40	M3 - M14	1	19	65	36	7
405.16.20	BT 40	M5 - M22	2	31	93	53	12
405.16.36	BT 40	M14 - M36	3	48	166	78	20
505.16.12	BT 50	M3 - M14	1	19	100	36	7
505.16.20	BT 50	M5 - M22	2	31	105	53	12
505.16.36	BT 50	M14 - M36	3	48	142	78	17,5

Hinweis: Für Bearbeitungszentren ohne Synchronspindel.
Note: For machining centres without synchronous spindle.
Observation: Pour centres d'usinage sans broche synchrone.

